

**REACH**

Eloy de Lera Acedo  
Cavendish Laboratory  
University of Cambridge, UK

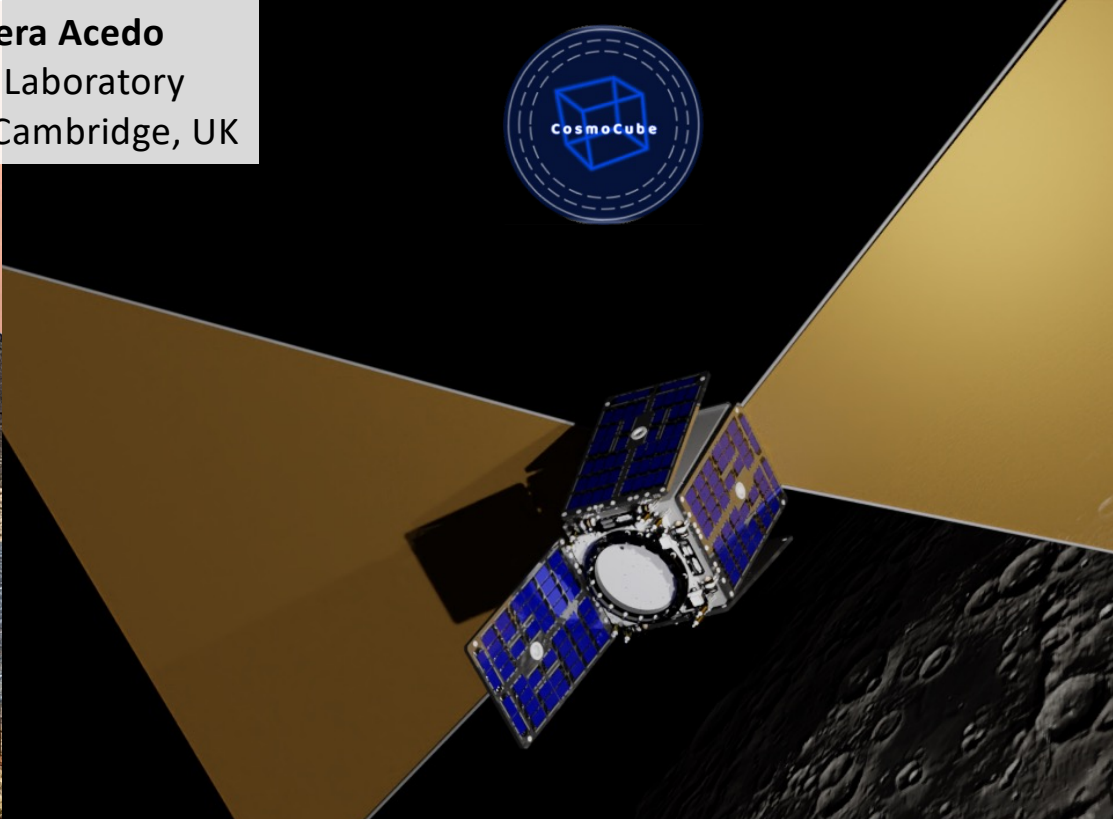

# Unveiling the Dark Ages and the Cosmic Dawn with **REACH** and **CosmoCube**

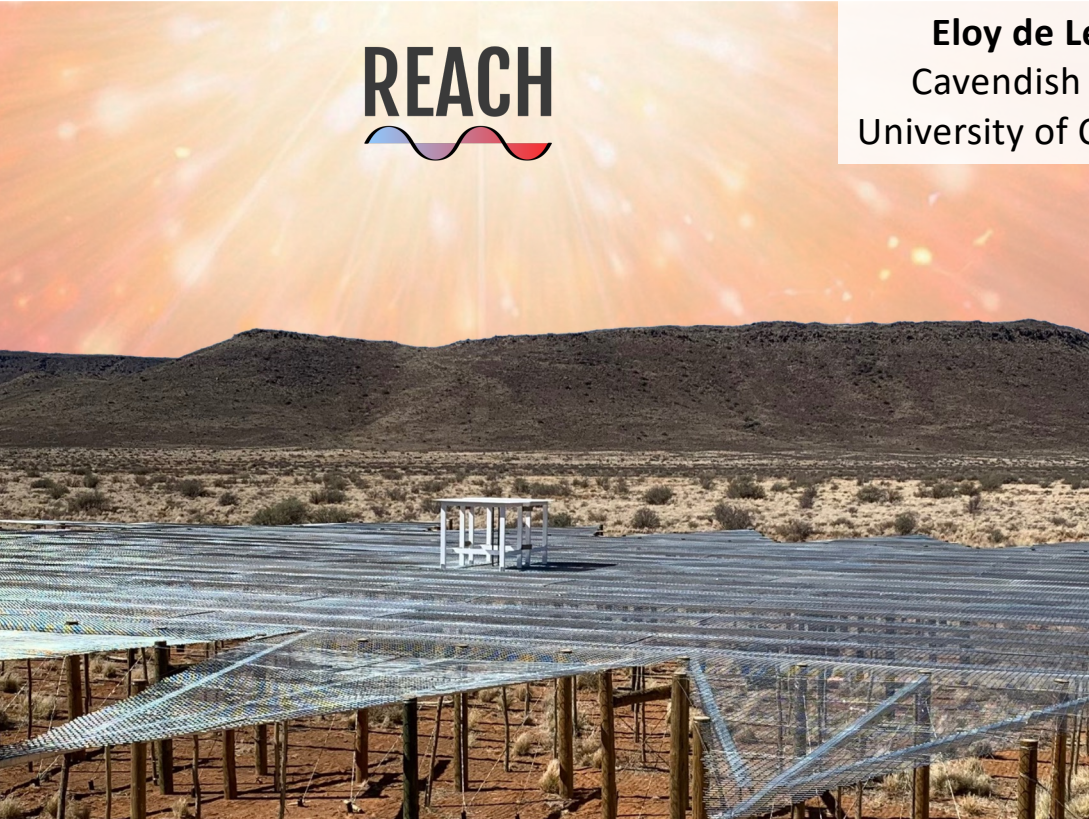

# Why 21-cm Cosmology?

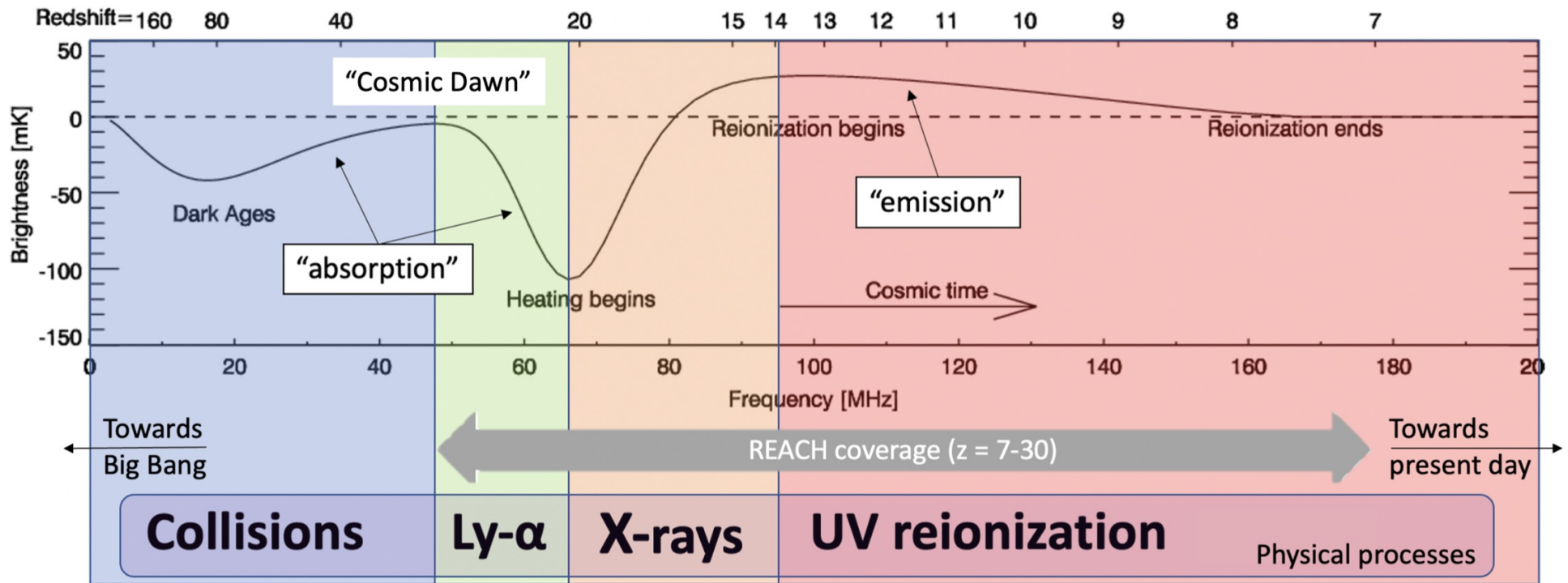

# Sky-averaged 21-cm Cosmology



LOFAR

MWA

HERA

SKA

21-cm power spectrum

Medium field of view  
21-cm spatial variations at spot  $z$   
Redshift coverage  $6 < z \lesssim 30$   
Medium-High cost - €€€[€]



EDGES

SARAS

LEDA

REACH

21-cm sky-averaged

Large field of view  
Continuous  $z$  probes → evolution  
Redshift coverage  $6 < z \lesssim 30$   
Low cost - €

# State of the Art in Observations

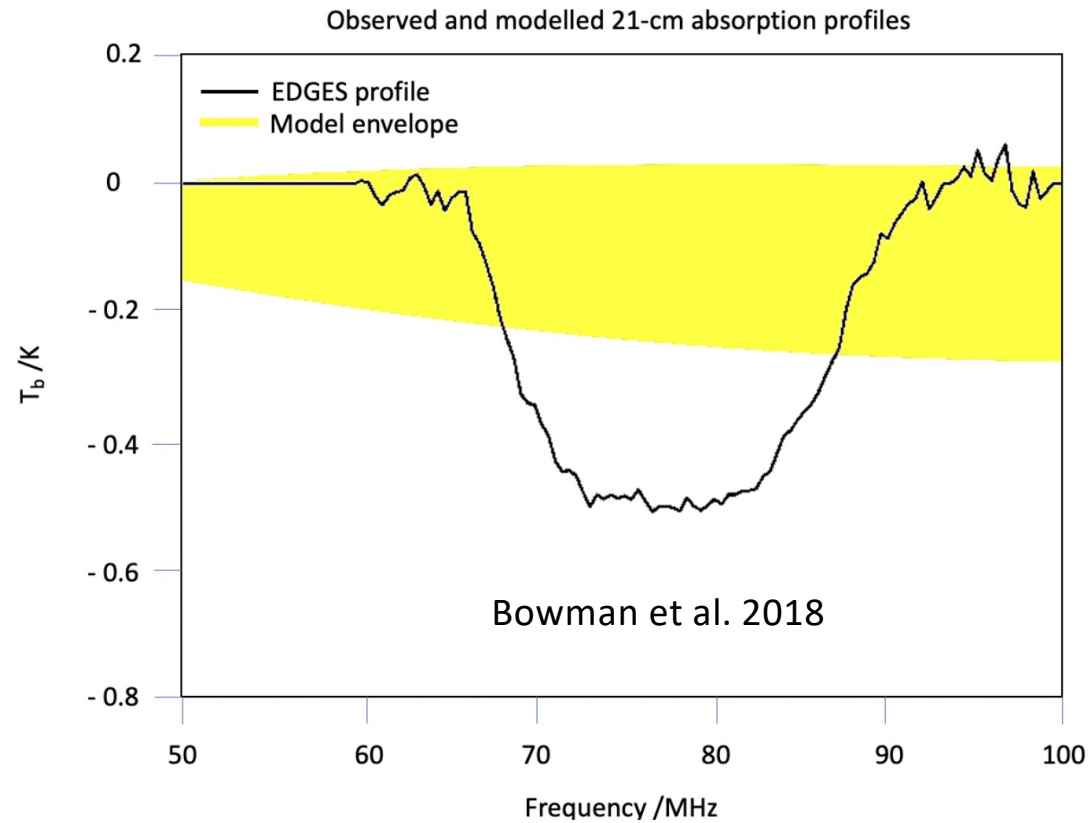

# State of the Art in Observations

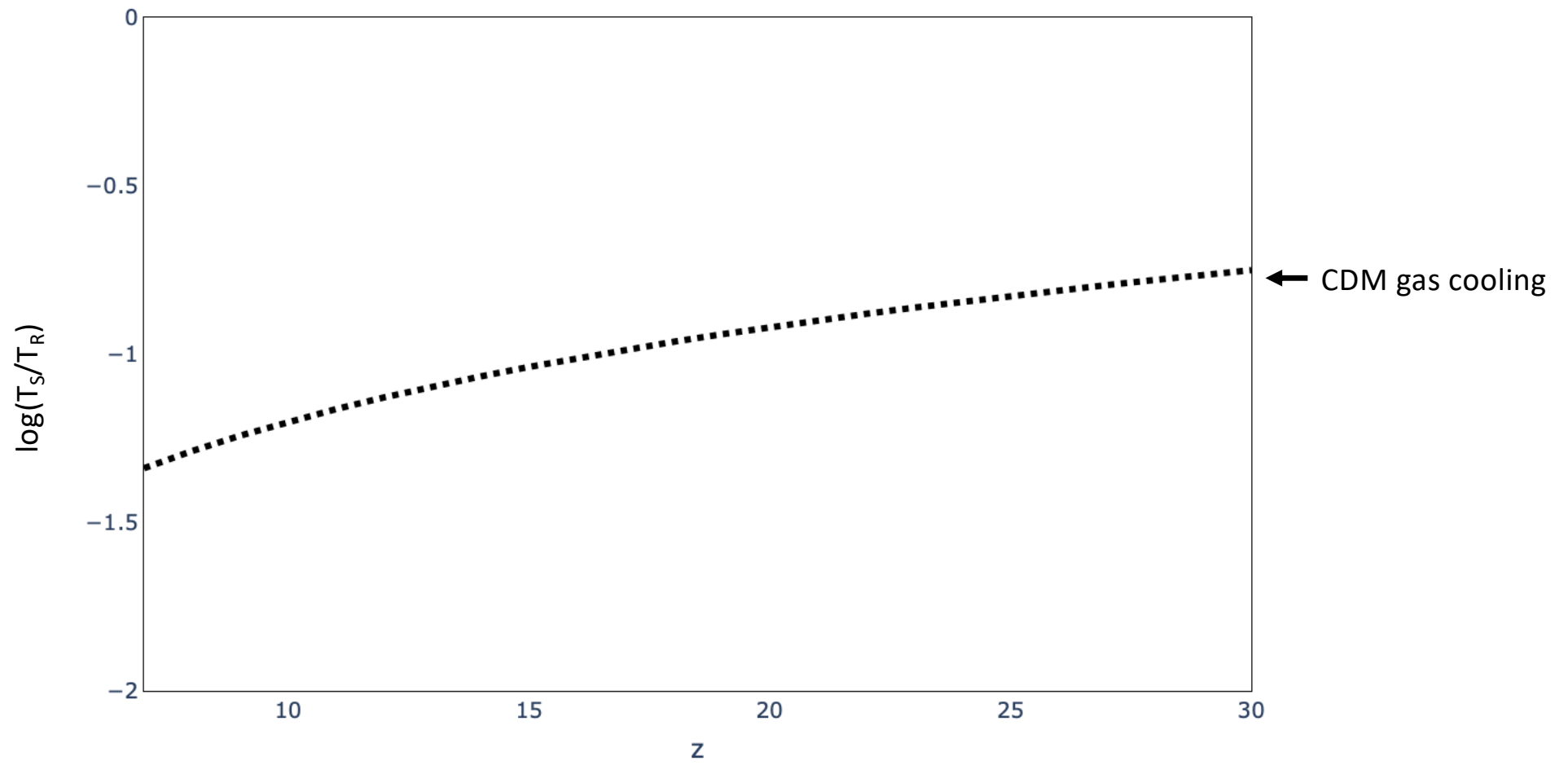

# State of the Art in Observations

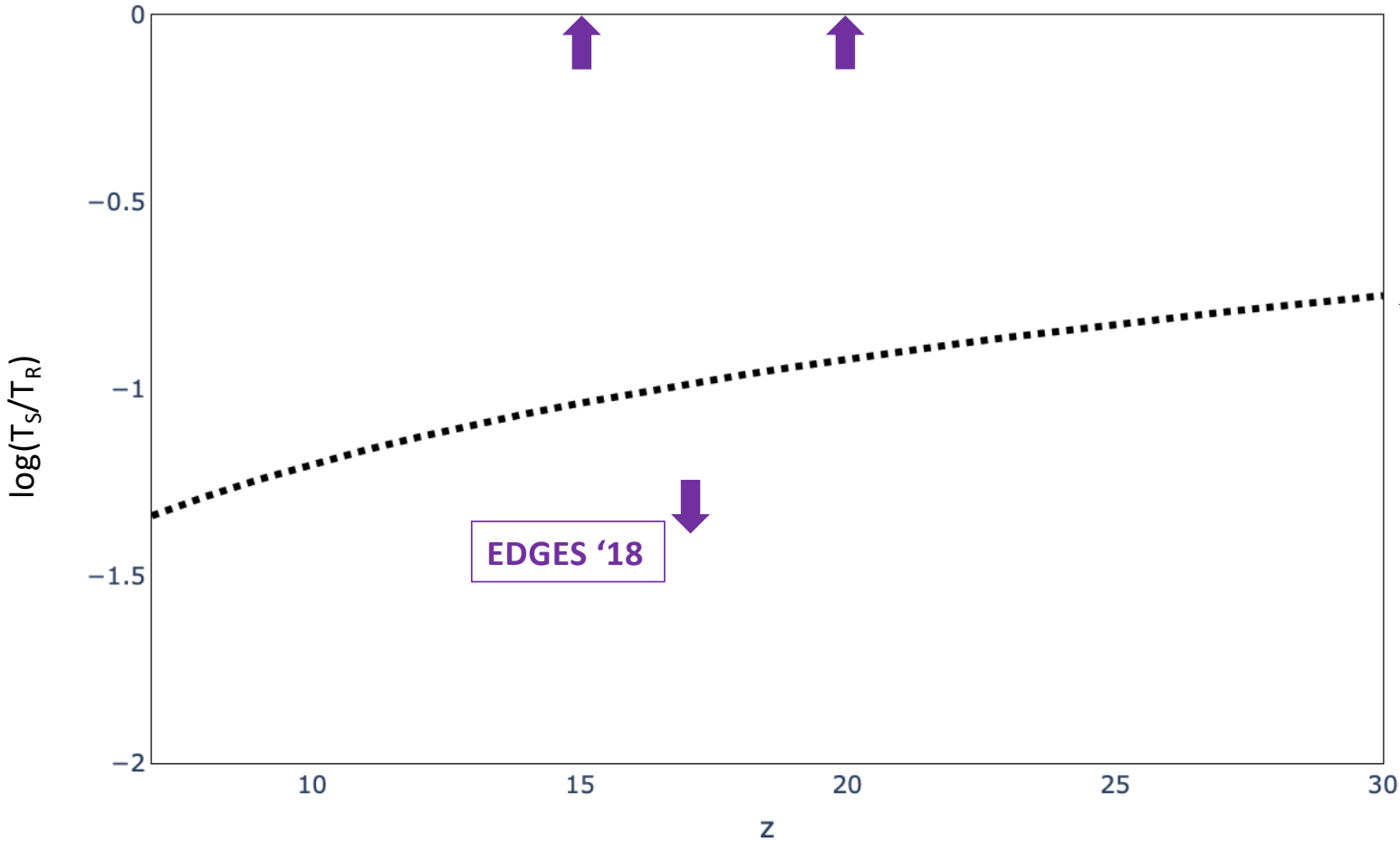

- Concerns on EDGES**
- Hills et al 2018
  - Sims et al 2018
  - Singh et al 2019
  - Bevins et al 2020
  - Singh et al 2021
  - Bevins et al 2022
  - ...

← CDM gas cooling

- Below this line:
- Extra radio background and/or
  - Excess HI gas cooling and/or
  - Systematic distortion

# State of the Art in Observations

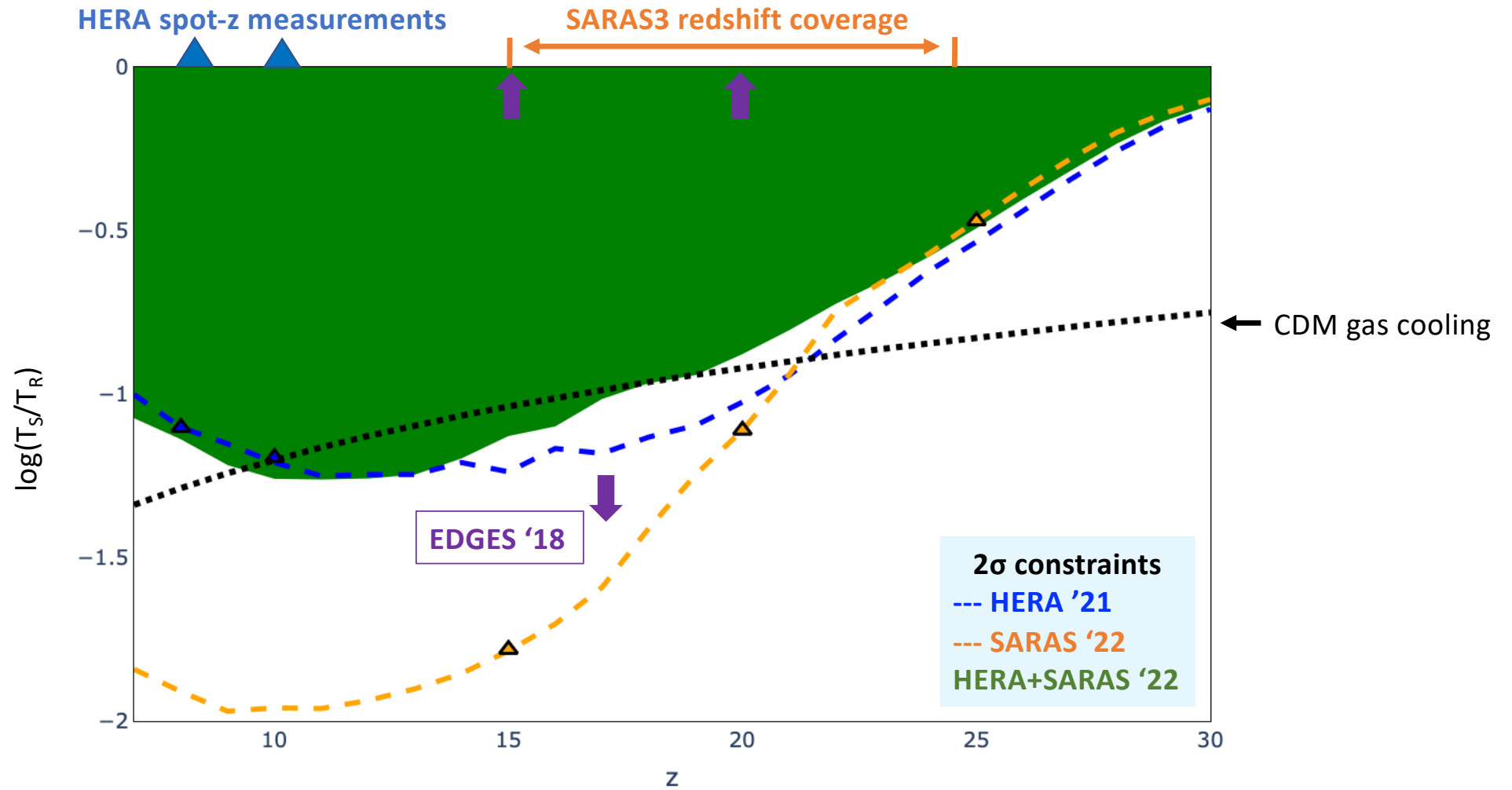

# What is REACH adding to these experiments?

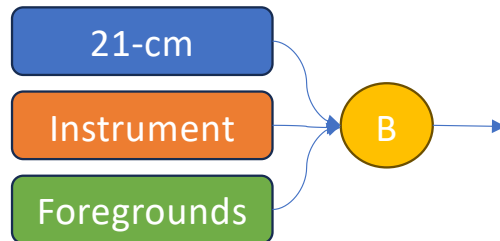

**Forward modelling pipeline:  
Full Bayesian joint analysis (21-cm  
signal, foregrounds, instrument)**

**Physical foreground models  
instead of low order polynomial  
models**

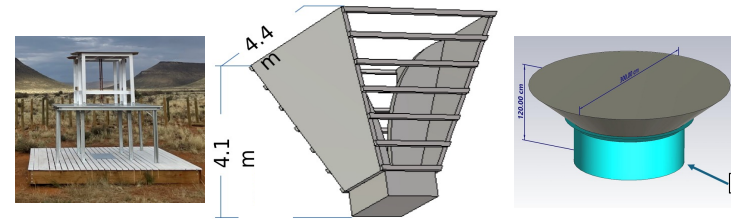
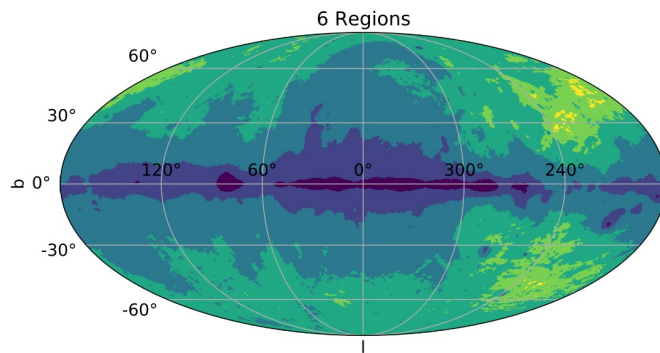

**Multi-antenna system:  
Simultaneous observations with  
different antennae**

**In-field calibrator: Live  
measurements of the system  
during observations**

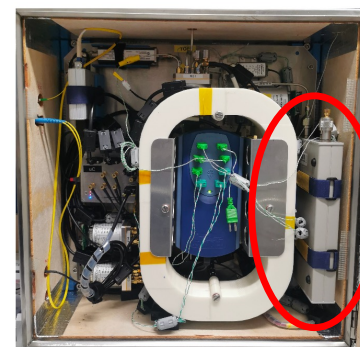

**Live measurements of the  
entire receiver.**

KAROO Radio reserve  
South Africa

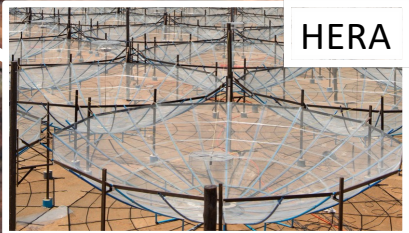
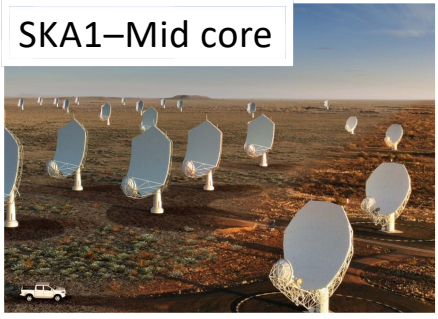
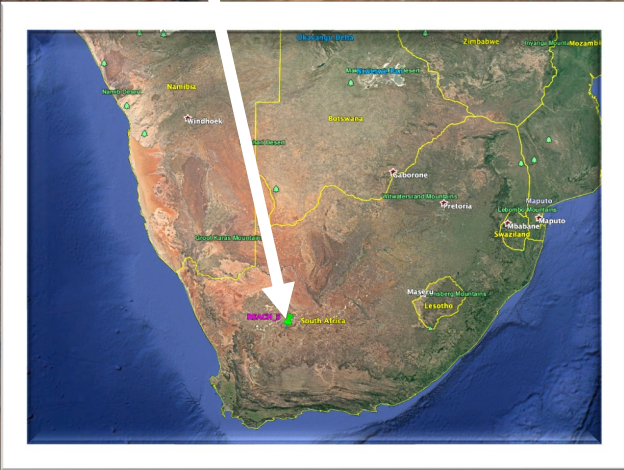

5 km

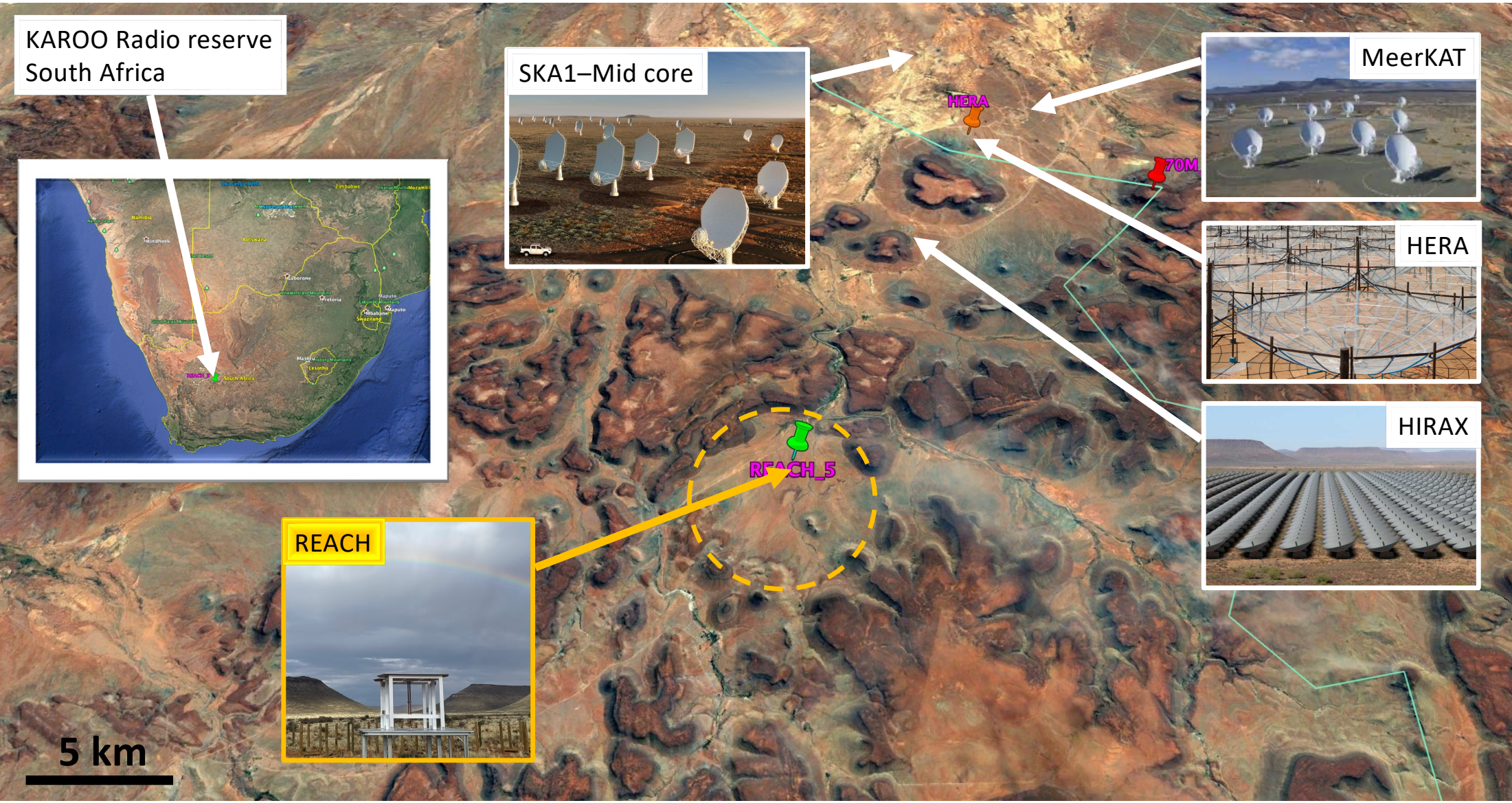
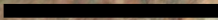

REACH 1<sup>st</sup> antenna



Solar-powered + satellite link



30 m elevated ground mesh

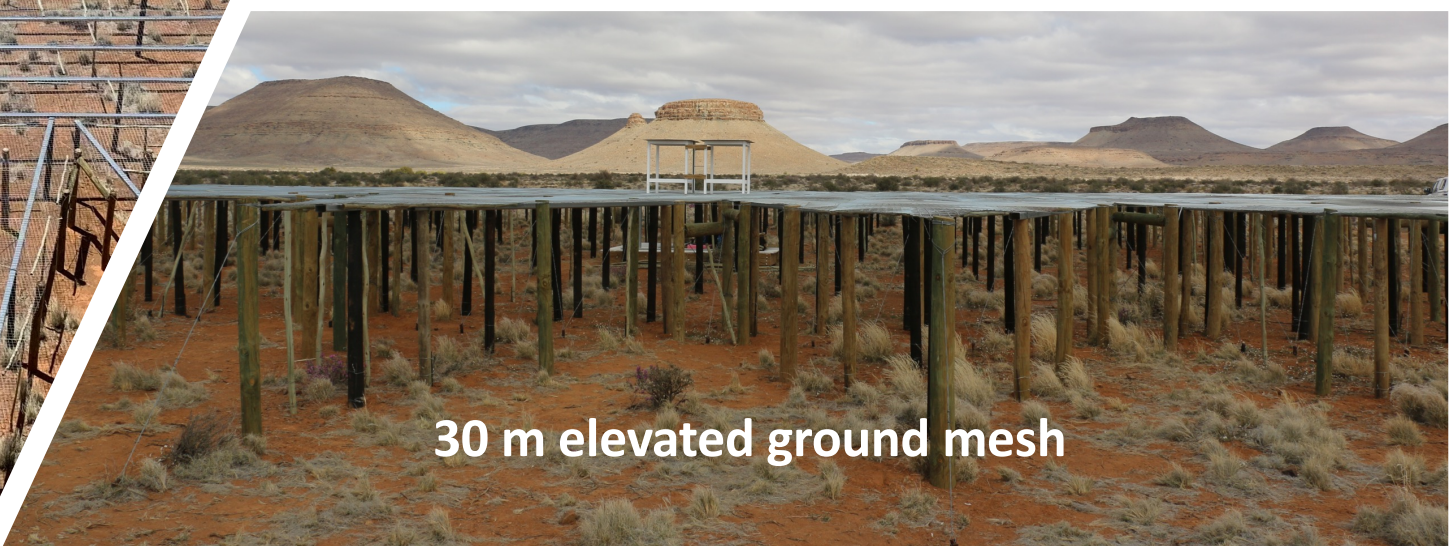

# Forward modelling

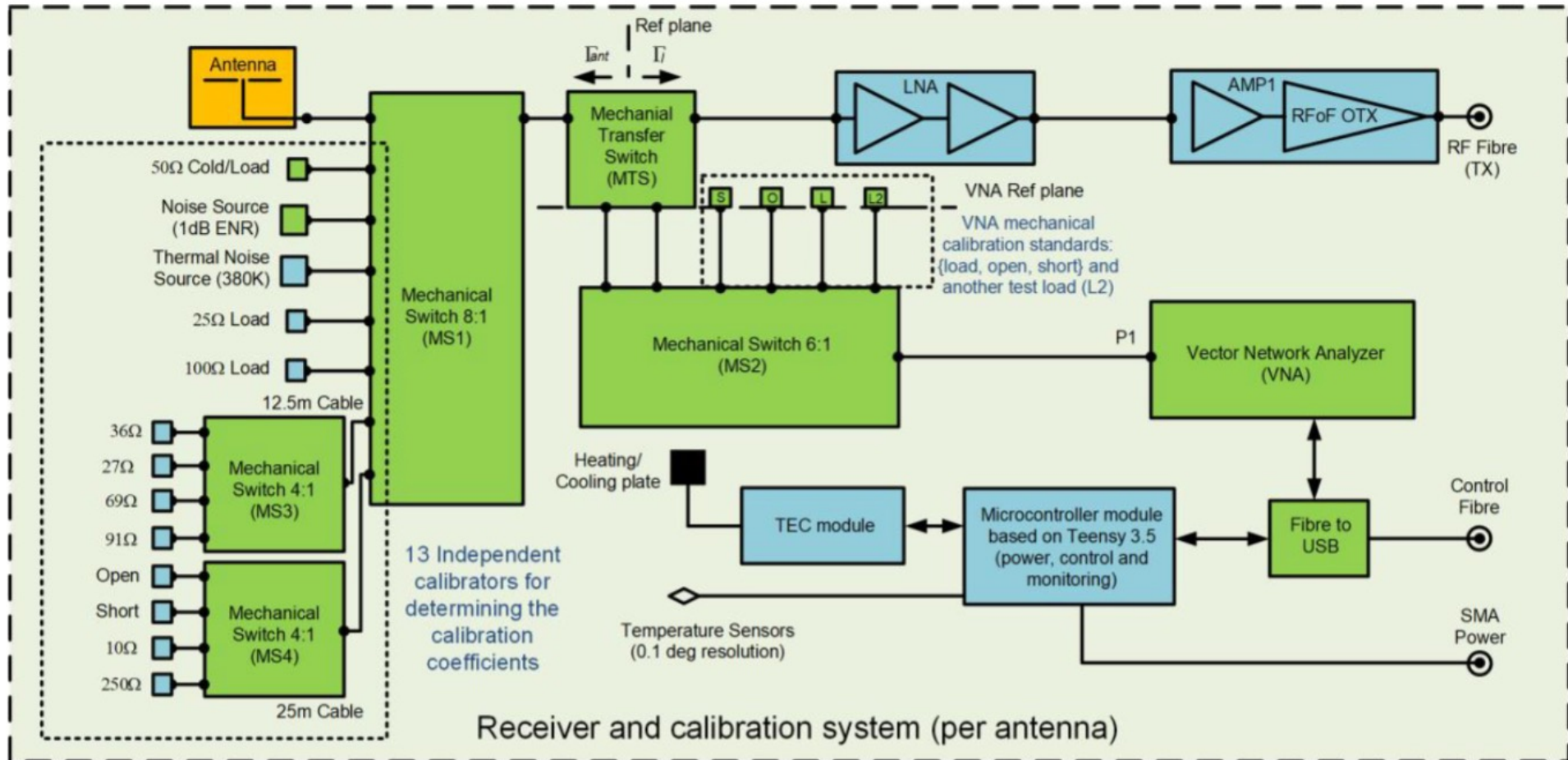

# Forward modelling

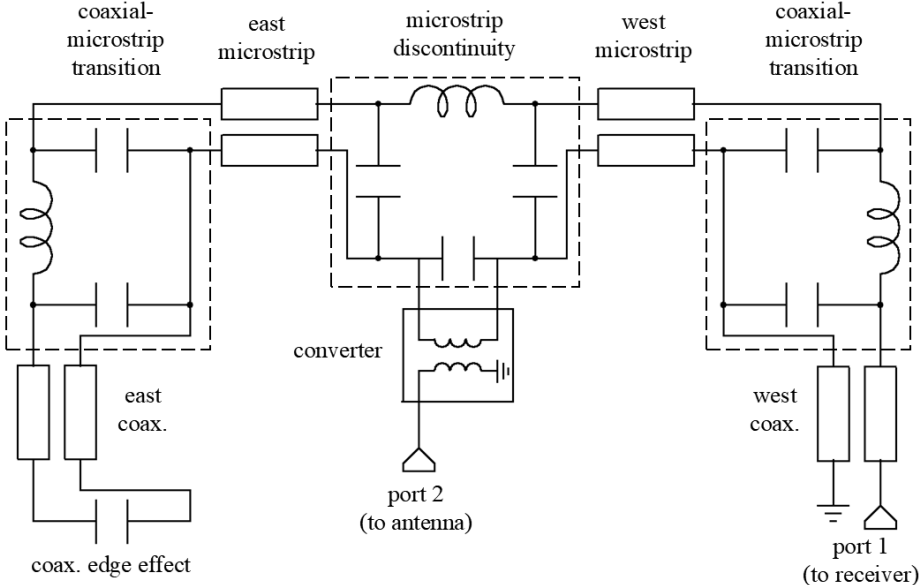
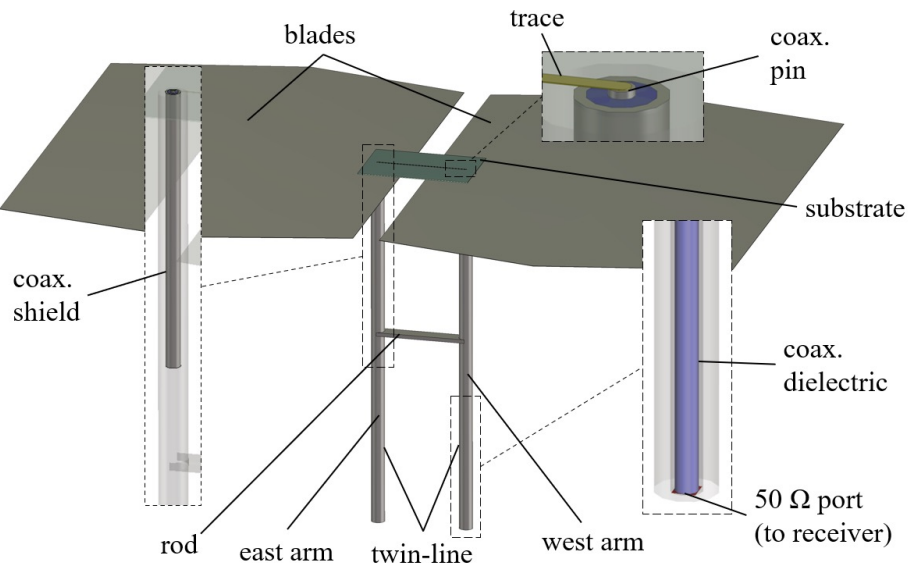

# Forward modelling

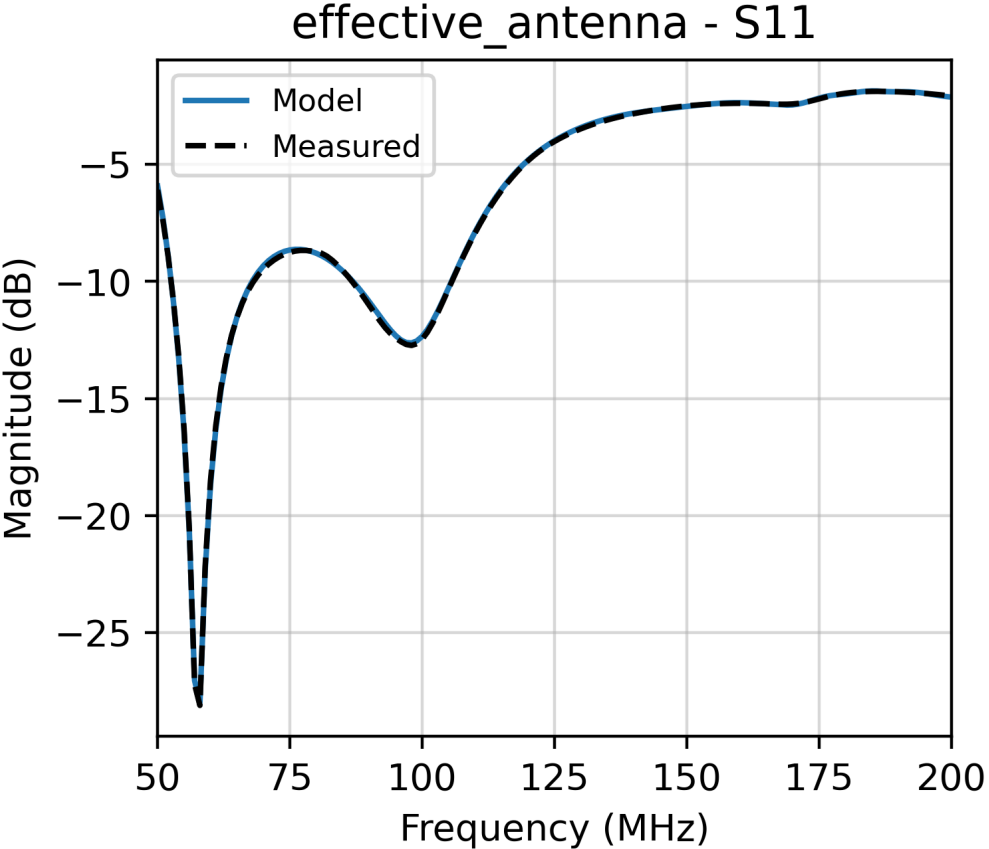

# Status of the receiver calibration

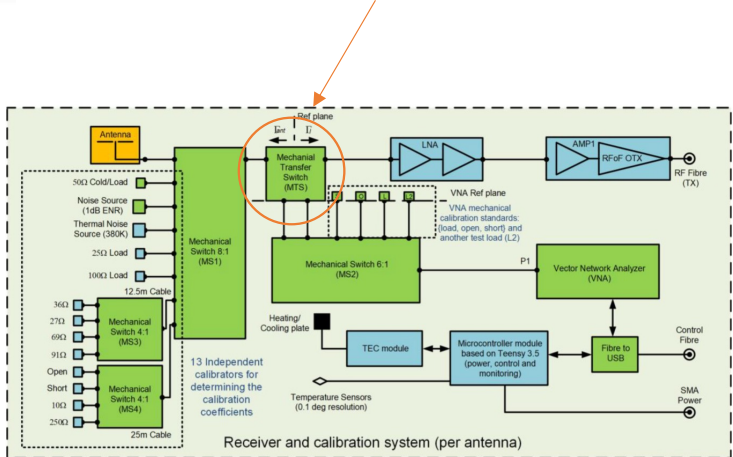
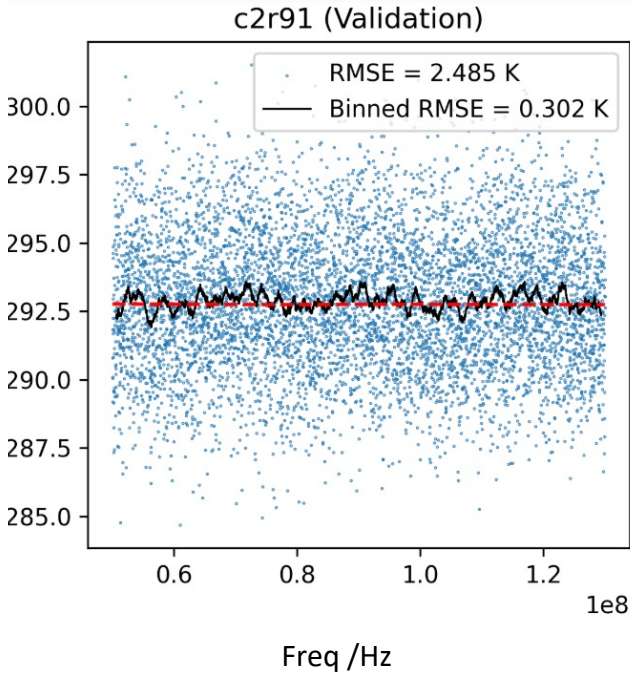
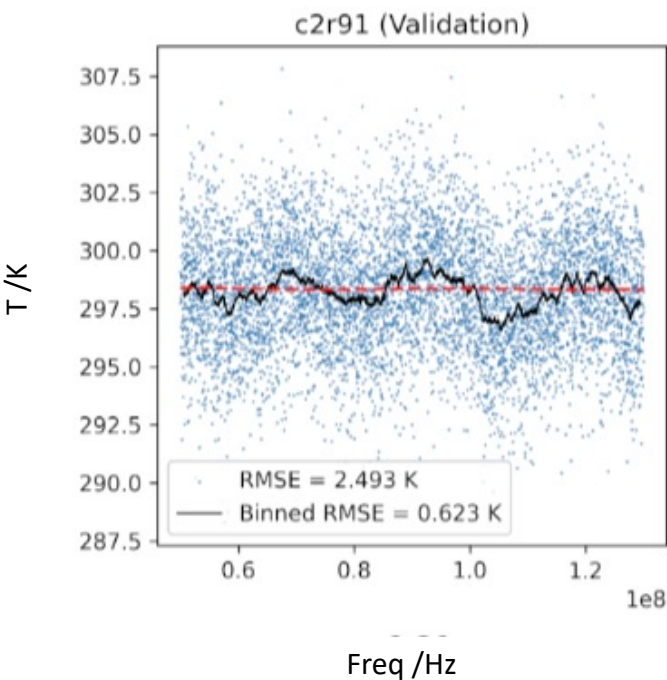

This is the impact of missing just 1 little switch in the calibration

# Status of the receiver calibration

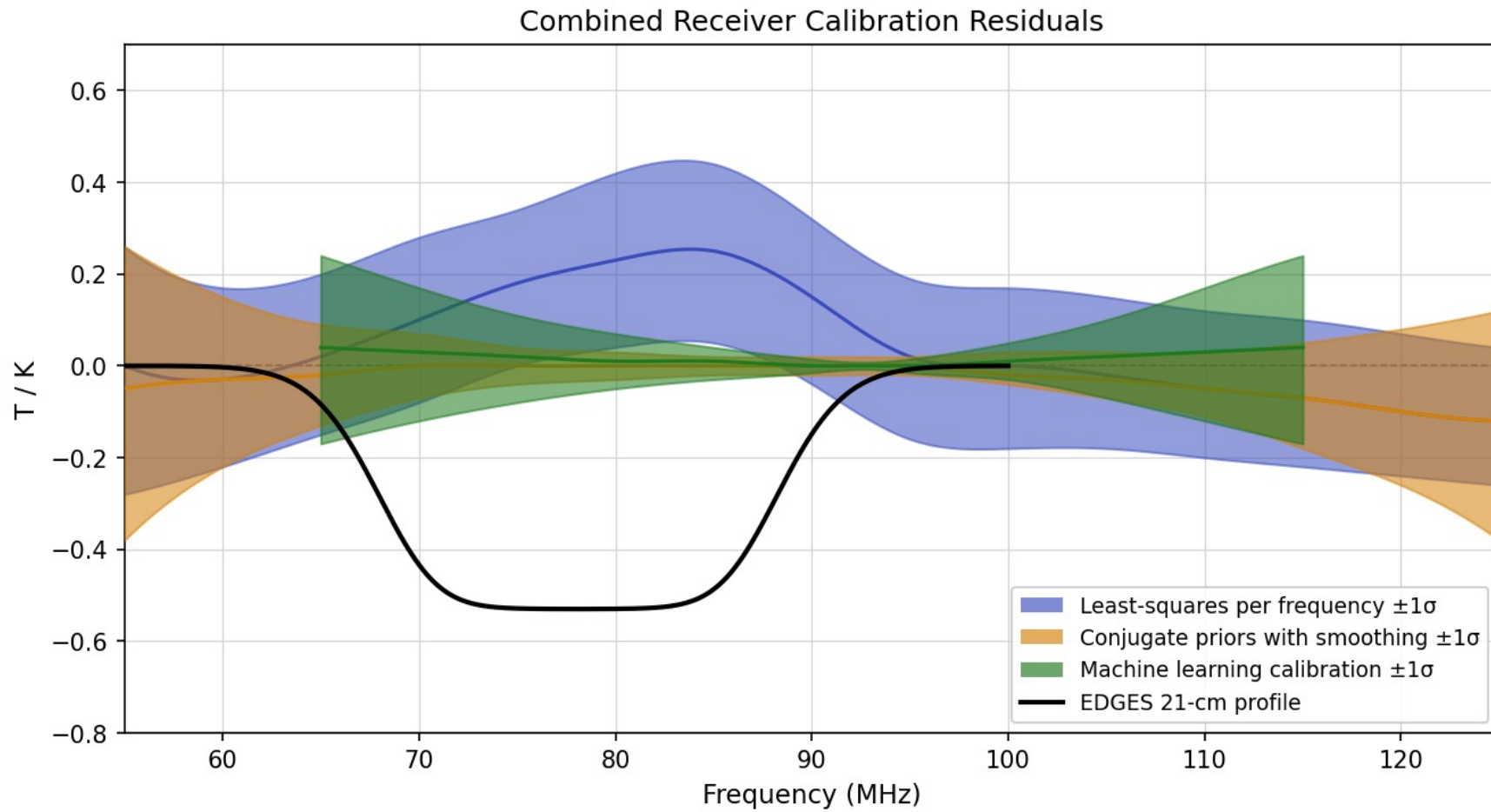

# Status of the data analysis

350h of sky data  
since last year

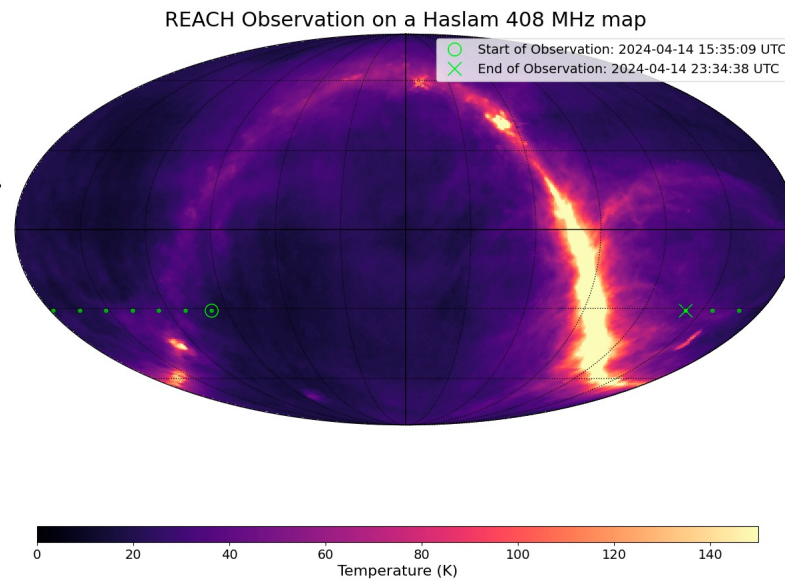
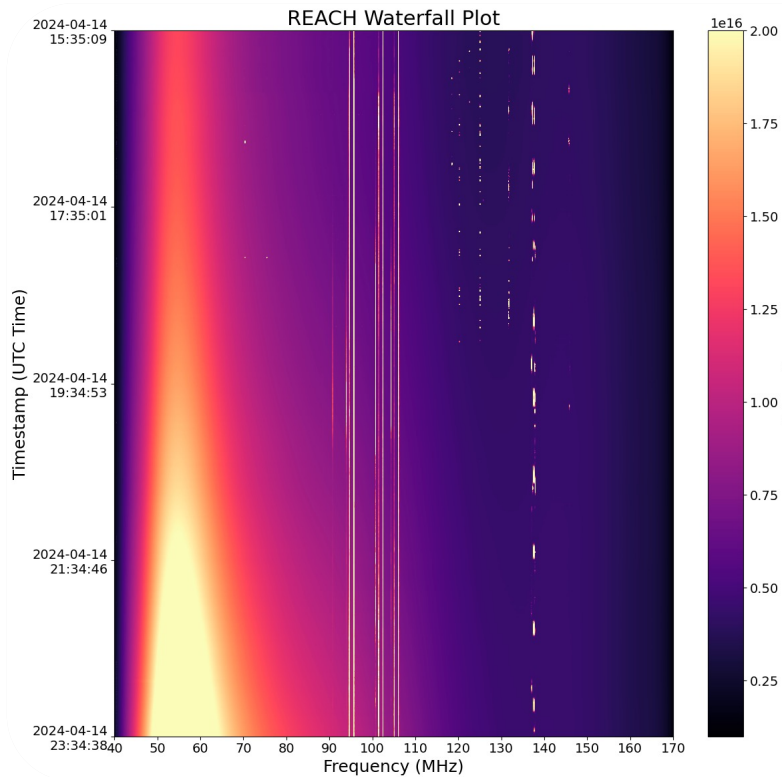

# On-sky data analysis

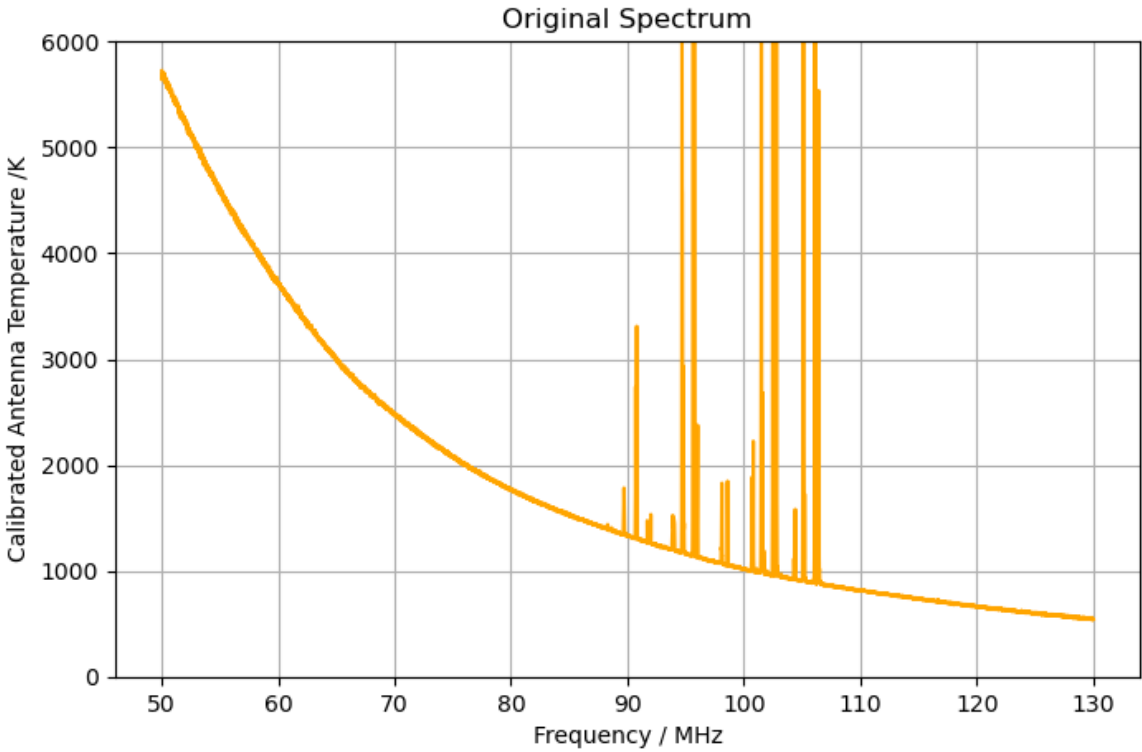

# On-sky data analysis

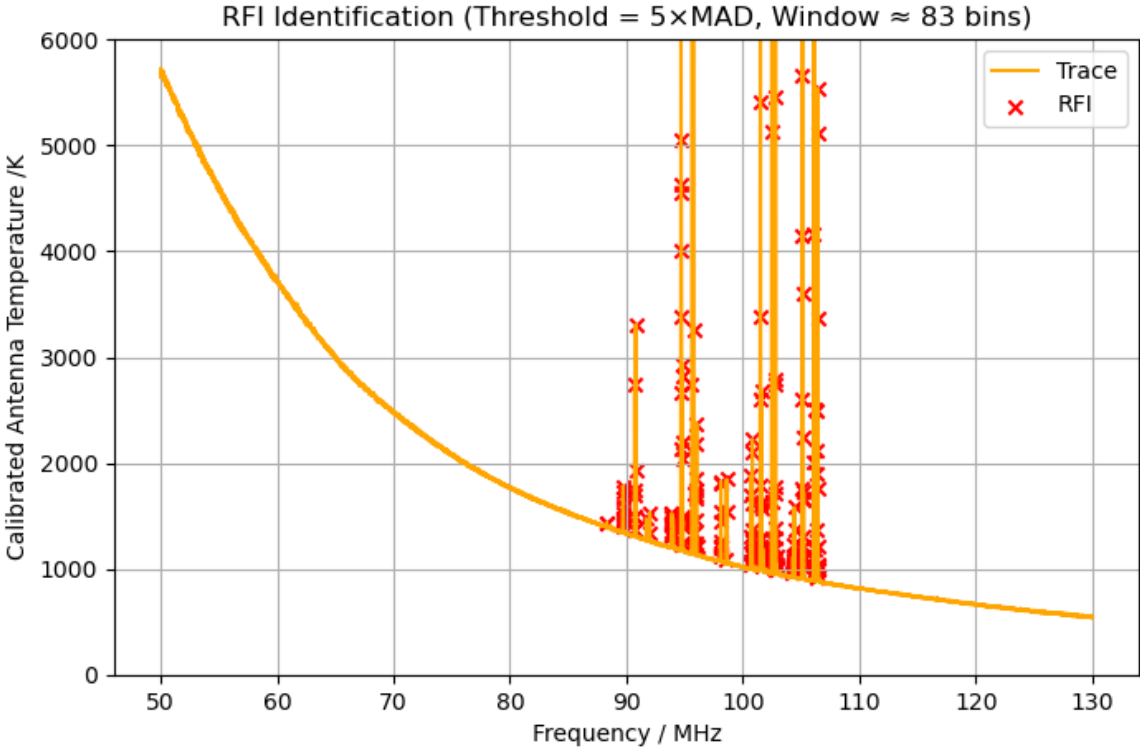

# On-sky data analysis

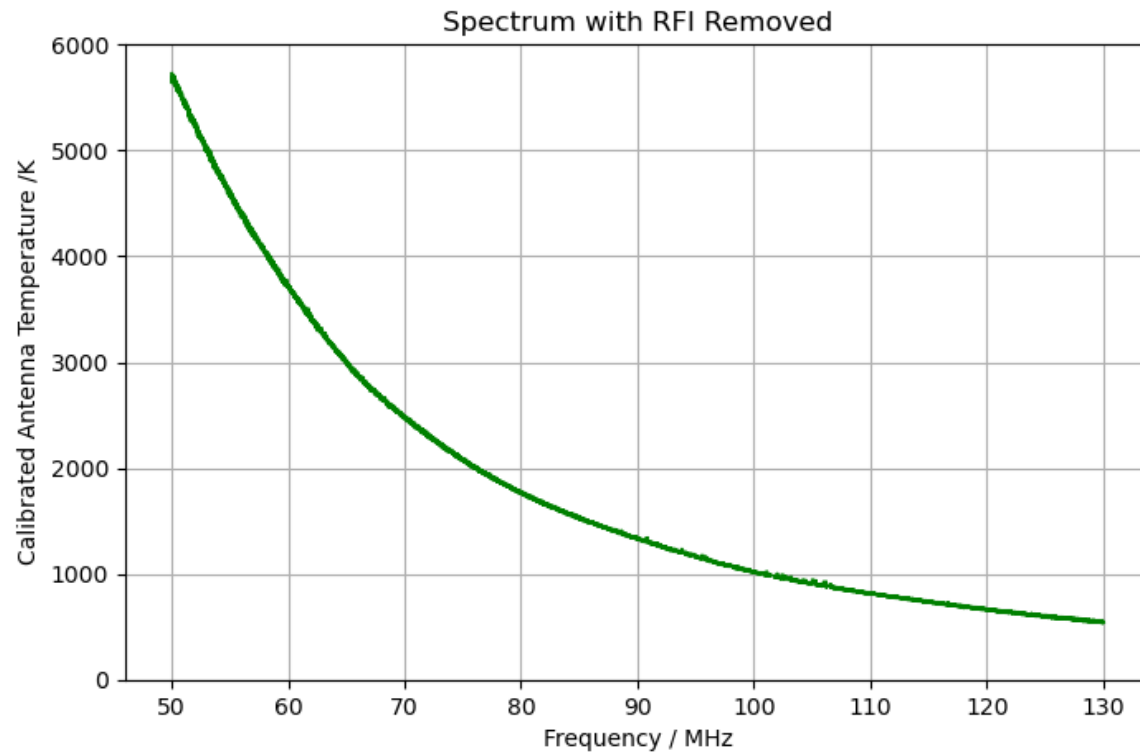

# Foreground science

REACH - All-sky brightness amplitude fits at 75 MHz after absolute calibration

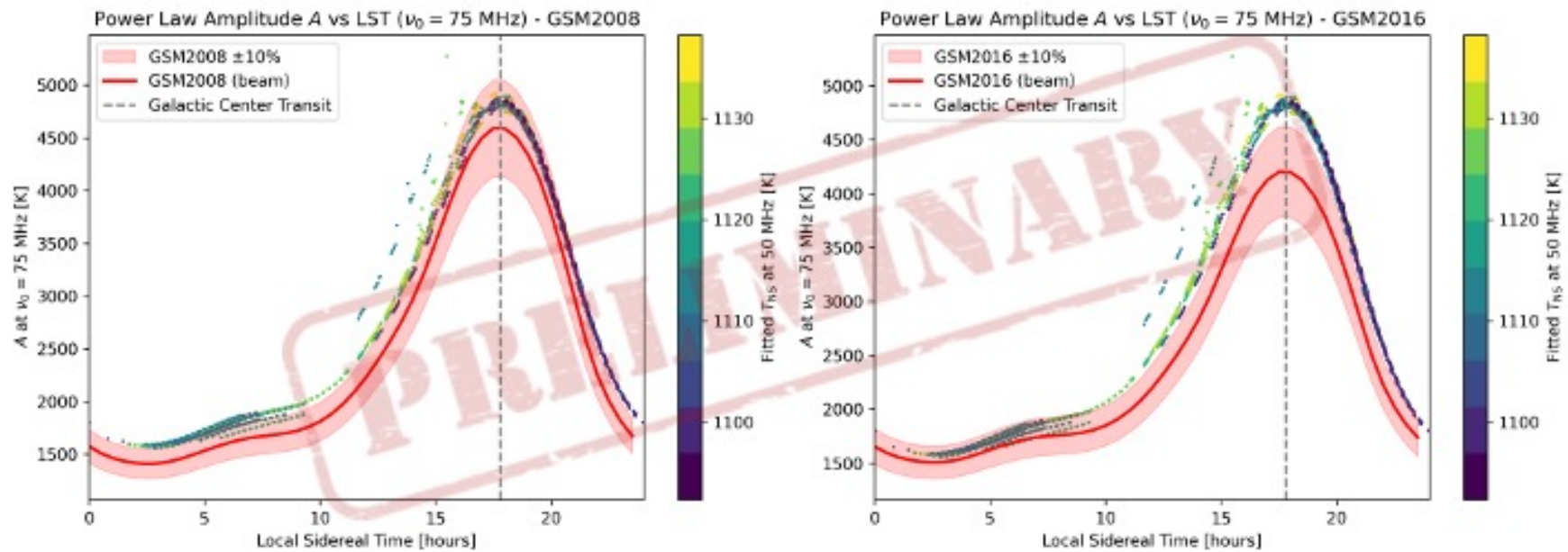

Credit: REACH collaboration

# Hunt for the 21-cm line

Just 1 night observation with the galaxy below horizon

November 25

REACH

Forward-Modelling pipeline



-- UNPUBLISHED RESULTS -- PLOT REMOVED --

# Hunt for the 21-cm line

Just 1 night observation with the galaxy below horizon

November 25

EDGES/SARAS3-like analysis  
(low order models)



-- UNPUBLISHED RESULTS -- PLOT REMOVED --

# If you want to know more...



Journal Articles

Conference Proceedings

**[42] Quantifying the impact of lunar and planetary occultation on experimental global 21 cm cosmology**

Joe H. N. Pattison, Dominic J. Anstey, Eloy de Lera Acedo

Monthly Notices of the Royal Astronomical Society

March 2026

**[41] Capturing system drift with time series calibration for Global 21-cm cosmology experiments**

Christian J. Kirkham, Dominic J. Anstey, Eloy de Lera Acedo

Monthly Notices of the Royal Astronomical Society

March 2026

**[40] The Magnitude of the Dark Ages 21 cm Signal in the Context of Existing Early and Late Time Constraints on  $\Lambda$ CDM**

ut/CommonHTML/jax.js



# Why are we thinking on space then?

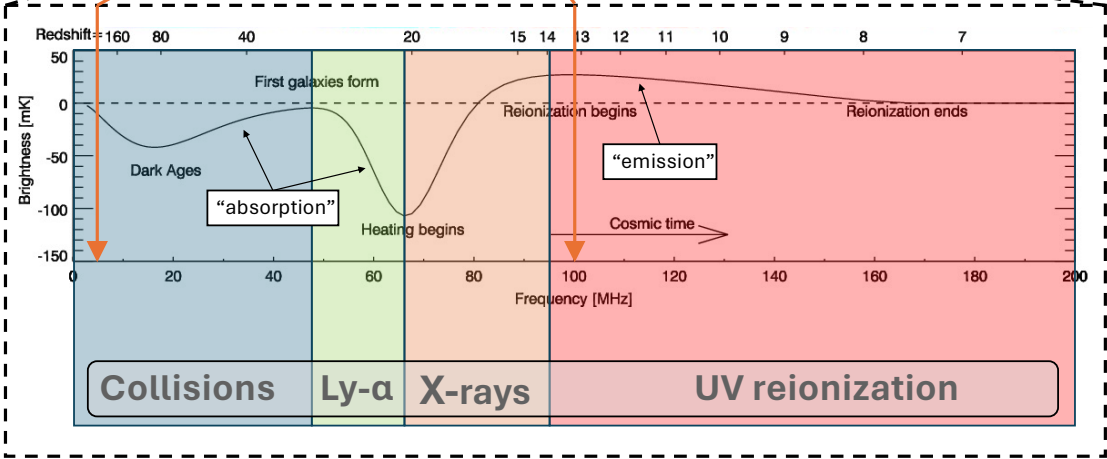
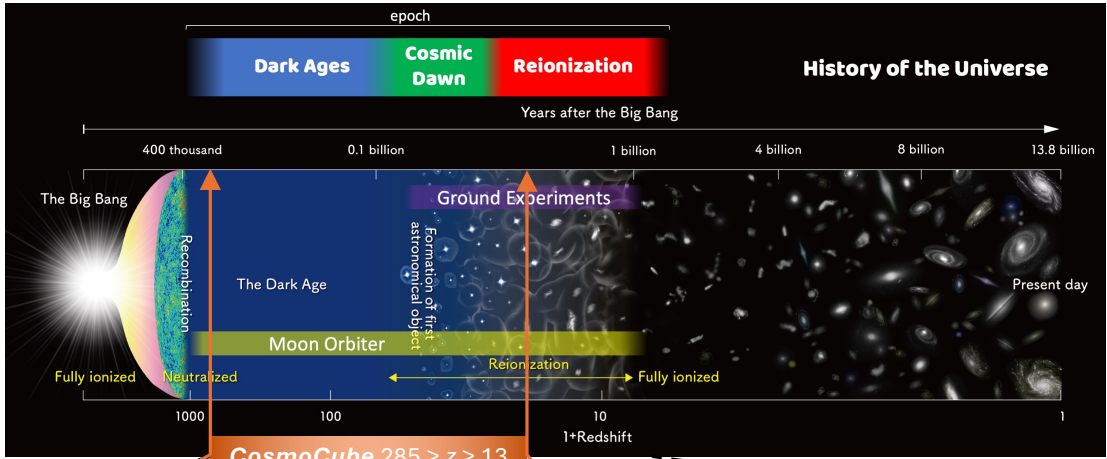

# Challenges on the ground

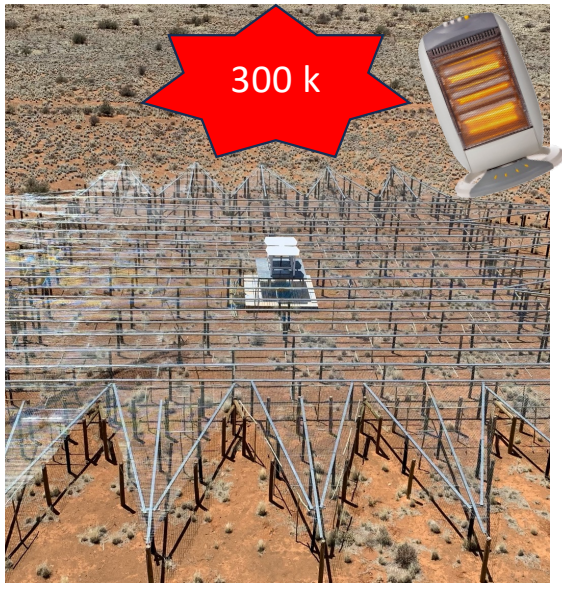
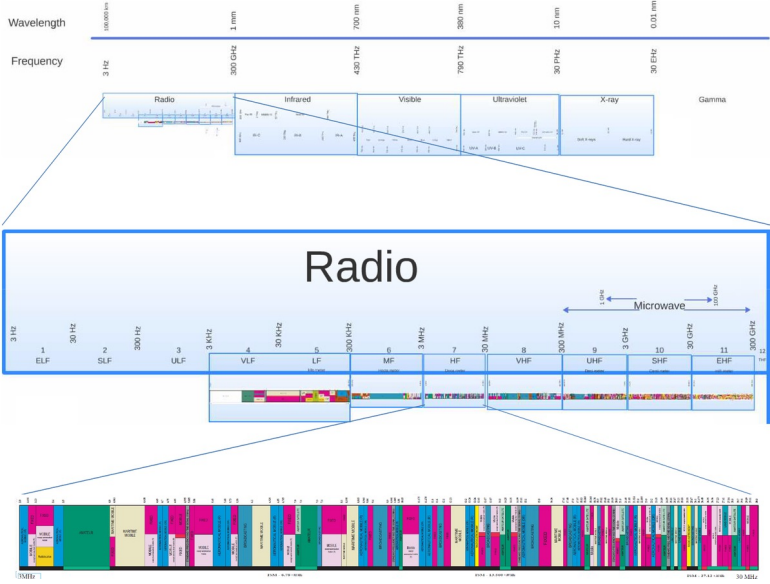
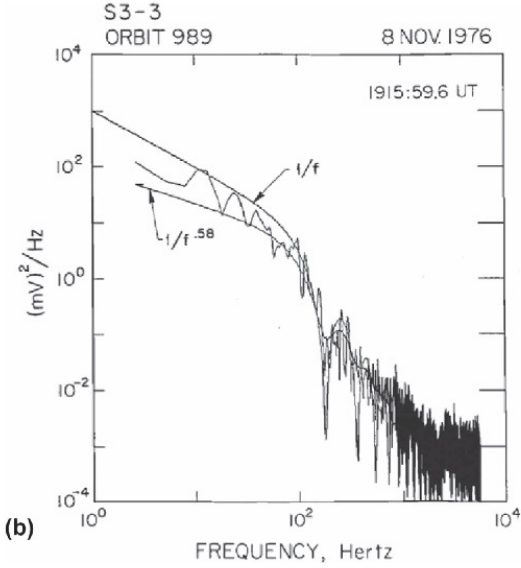

Earth's Ionosphere

RFI

Near field emissions

# Solutions in space

Earth's Ionosphere

RFI

Near field emissions

A **space mission** on  
the **far side of the**  
**Moon**, in **orbit**

Unique opportunity  
if humankind's  
history, first time we  
are capable of doing  
this, but maybe the  
last time too...

<sup>^</sup> de Lera Acedo et al., 2026, in review. (Nat Ast)



# Science goals

**First 21-cm Dark Ages Detection** - Global 21-cm absorption profile at  $30 < z < 285$  (5–45 MHz), probing the Universe  $\sim 4$ –100 Myr after the Big Bang.

**Mid-Redshift Hubble Constant** - Constrain  $H(z \approx 80)$

**Dark Matter Physics** - Inform DM–baryon scattering cross-sections

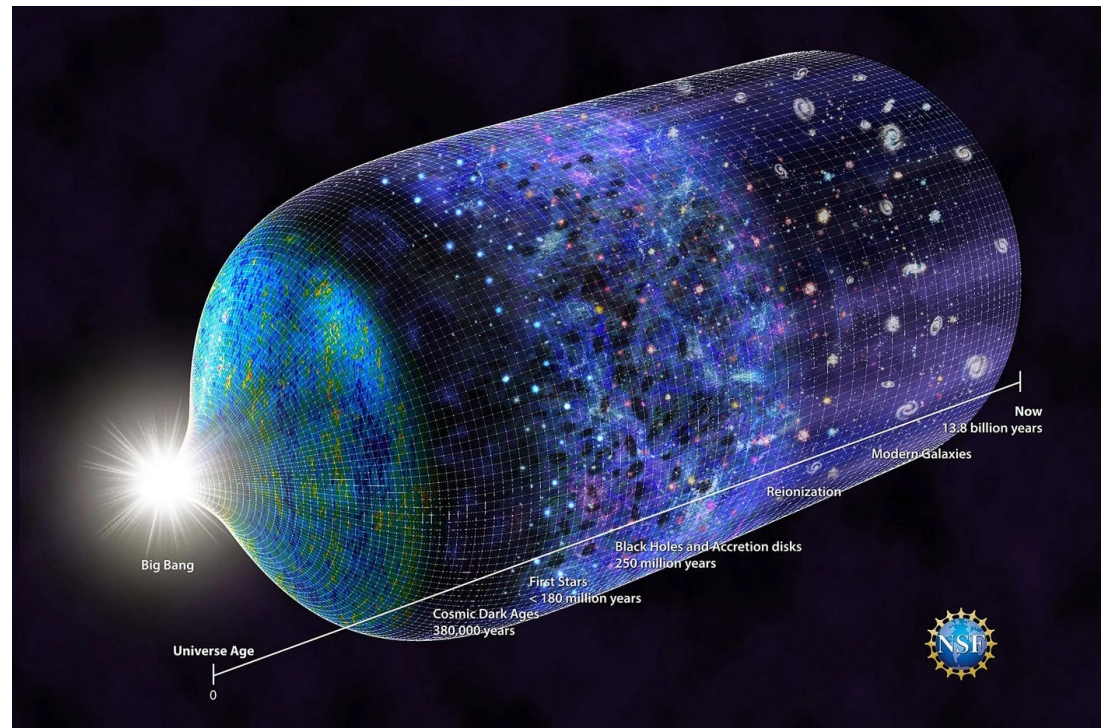

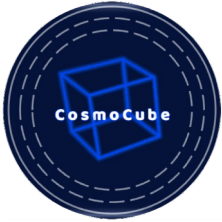

# The Moon is back on the agenda

Single antenna lander



Surface array

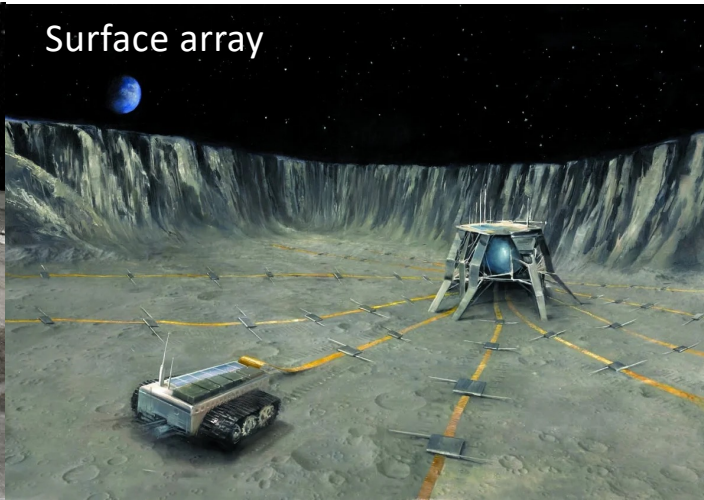

Orbiter array

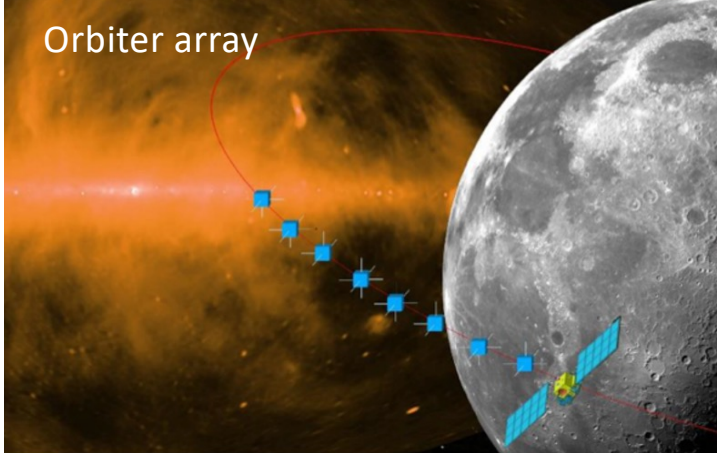

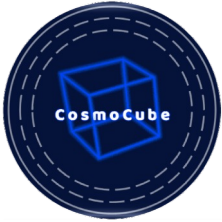

# The Moon is back on the agenda

Single antenna lander



Surface array

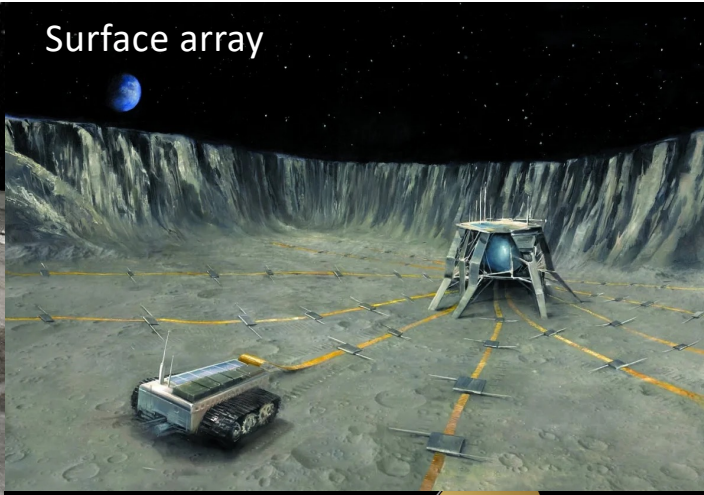

Orbiter array

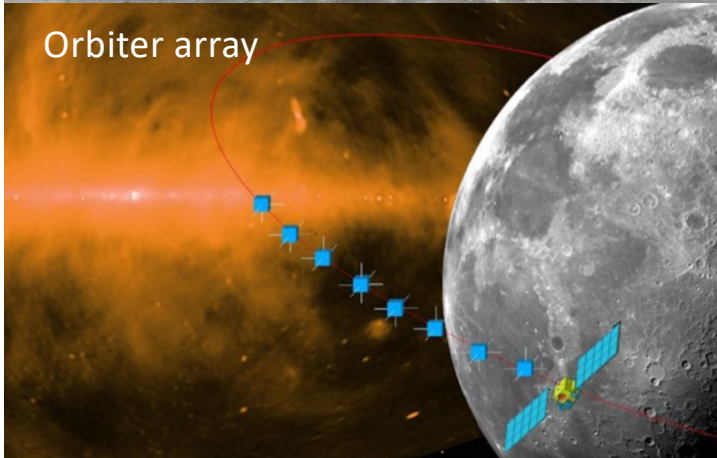

Orbiter

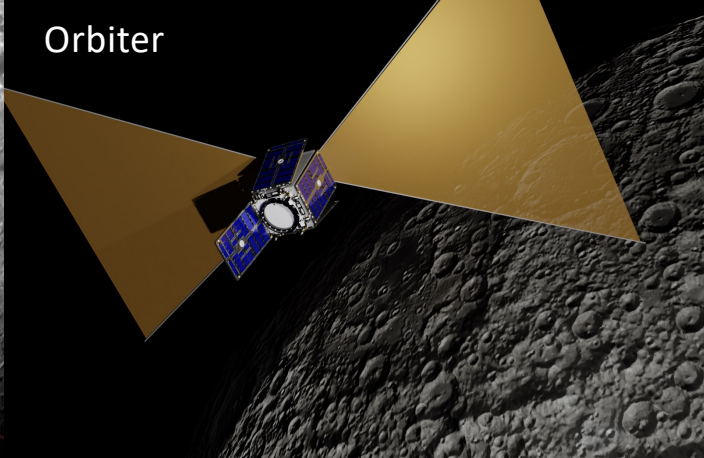

Funding



Core members



UNIVERSITY OF  
CAMBRIDGE



UNIVERSITY OF  
PORTSMOUTH



Collaborators



**Jet Propulsion Laboratory**  
California Institute of Technology

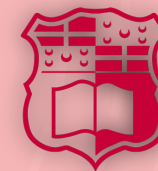

L-Università  
ta' Malta



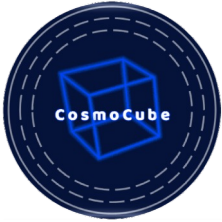

# The platform and payload

## 2.- Integrated radiometer

- Using COTS RFSoc technology
- Dicke-switch calibrator



**SSTL-21**

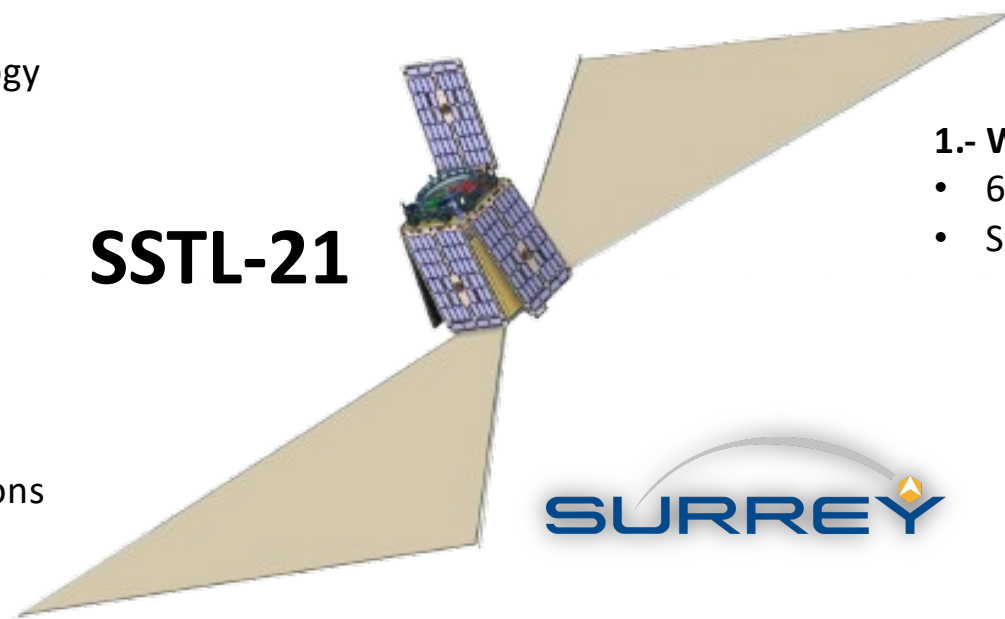

## 1.- Wideband deployable antenna

- 6 m long once deployed
- Stowed during launch

## 3.- Thermal control



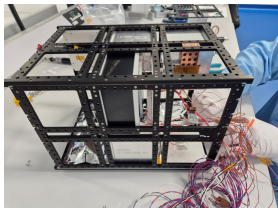



- 1 mK rms during observations



\* *Kaan and de Lera Acedo, RASTI 2024*  
~ *Zhu, de Lera Acedo et al., RASTI 2024*

# The orbit



	Circular polar orbit	LLO 100	Frozen orbit 41x190	Frozen orbit 70x166	Frozen orbit 100x199	Frozen orbit 90x190
						
Hp x Ha (km x km)	100 x 100	100.58 x 100.62	41 x 190	70.537 x 166.663	100x199	90x190
a (km)	1837.4	1838.00	1853.201	1856	1887.117	1877.3639
e	0	1.00E-05	0.04036	0.025896	0.026291	0.0266139
i (deg)	90	94	90	91	90	90
RAAN (deg)	0	0	0	0	0	0
AoP (deg)	270	90	270	270	270	270
M (deg)	0	0	0	0	0	0
Time in RF shield per year [hr]	998	1023.7	957	955	840	872
Time in RF shield and Sun eclipse per year [hr]	389	415.72	363	373	307	324
Minimum lifetime for 1296 in RF shield [years]	1.30	1.27	1.35	1.36	1.54	1.49
Minimum lifetime for 1296 with in RF shield and Sun eclipse [years]	3.33	3.11	3.57	3.47	4.22	4



# Mission status

ESA mini-F proposal

ESA-SCI-DIR-AO-014: CosmoCube: Conquering the Cosmic Dark Ages from the Moon 1

**Exploratory Call for a mini-Fast mission in ESA's Science Programme**  
Reference: ESA-SCI-DIR-AO-014

**Proposal Title**  
CosmoCube: A Mini-Fast Lunar Observatory for 21-cm Cosmology of the Dark Ages

**Lead Proposer**  
Dr. Eloy de Lera Acedo  
Cavendish Laboratory, University of Cambridge  
JJ Thomson Avenue, Cambridge CB3 0HE, United Kingdom  
Email: [ed330@cam.ac.uk](mailto:ed330@cam.ac.uk)  
Phone: +44 (0)1223 337365

ESA-SCI-DIR-AO-014: CosmoCube: Conquering the Cosmic Dark Ages from the Moon 1C

<p><b>University of Cambridge</b></p> <p>Dr. Eloy de Lera Acedo Dr. Domenico Anselmi Dr. Harry Davies Mr. Kaan Arslan Dr. Mohammed Al-Badri Dr. Shihab Mital Dr. Quentin Guenning Dr. John Curran</p>	<p><b>NASA Jet Propulsion Laboratory</b></p> <p>Dr. Charles Lawrence Dr. Tzu-Chang Chang Dr. Oliver P. Dore Dr. Michael D. Sierfert Dr. Jordan Mirocha Dr. Christopher Anderson</p>	<p><b>University of Malta</b></p> <p>Prof. Alessio Magro</p> <p><b>LSS</b> Large Space Structures GmbH</p> <p>Dr. Lutz Richter</p>
<p><b>University of Portsmouth</b></p> <p>Prof. David Bacon Dr. Van Monner-Almonson Dr. Clugbenga Oluwadina Dr. Chris Pattison Dr. Olesia Umsh</p>	<p><b>SURREY</b> Surrey Satellite Technology Ltd.</p> <p>Mr. Steve Eckersley Mr. Andrew Eard Mr. Ben Stern Mr. Andrew Palfreyman Mr. Jonathan Friend Ms. Tilia Maggia Mr. Gavin Johnston Ms. Stephanie Nottingham Dr. Andrea Turconi Dr. Anja-Maria Sorobot Dr. Nicolo Bernardini</p>	<p><b>INSPACE</b> 41211943</p> <p>In-Space Missions Ltd.</p> <p>Dr. Lucia King Dr. Theodora Varelidi-Strati</p> <p><b>ASU</b> Arizona State University</p> <p>Prof. Judd Bowman Dr. Daniel Jacobs</p>
<p><b>RAL Space</b></p> <p>Rutherford Appleton Laboratory Space</p> <p>Dr. Will Granger Dr. Chris Pearson Mr. Sunesh Bajaj Prof. Richard Holdaway</p>	<p>More information about CosmoCube in <a href="http://cosmocube.net">cosmocube.net</a></p>	<p><b>Embry-Riddle University</b></p> <p>Dr. Andri M. Gretarsson Dr. Yubin Liao</p>



Phase III  
2026-2031  
**est. £30M**

Phase II  
2023-2025  
£1.5M



Phase I  
2021-2022  
£0.15M

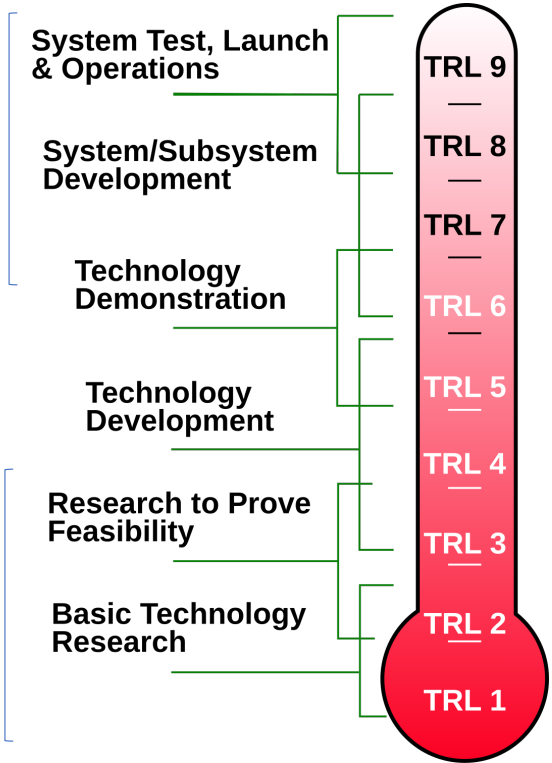

# Conclusions



- **REACH** from the ground:
  - “21cm monopole” at Cosmic Dawn and potentially EoR
  - “Good” data since March ‘25
  - Rapid improvement in data analysis
  - 2 new systems (South Africa and Cambridge) coming up
- **CosmoCube** from the Moon:
  - “21cm monopole” at Dark Ages and potentially Cosmic Dawn
  - In development. Funded by UKSA.
  - Follow the experimental procedure of ground experiments
  - Hoping to launch by end of the decade.

**REACH**

A banner with a red background and a colorful wavy graphic on the right. It features several logos: the University of Cambridge crest, the Kavli Institute for Cosmology Cambridge (KICC) logo, and the Cavendish Astrophysics logo. A QR code is also present.

UNIVERSITY OF CAMBRIDGE

Kavli Institute for Cosmology  
Cambridge  
KICC

CAVENDISH ASTROPHYSICS

CAVENDISH ASTROPHYSICS  
RADIO ASTRONOMY & COSMOLOGY



Consolidator  
Grant



## Kavli Fellowships

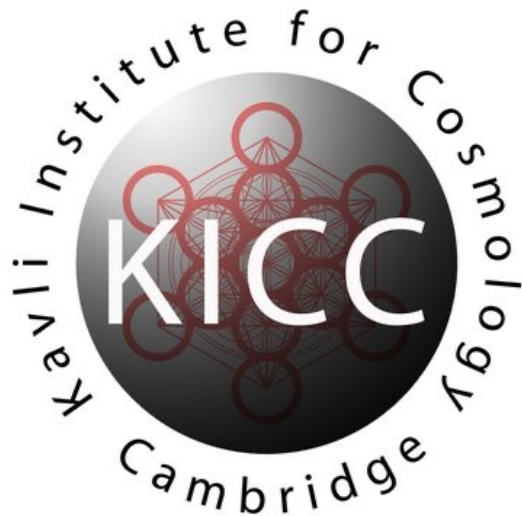

Do you consider yourself an instrumentalist/experimentalist in Cosmology?

Are you an Early Career / Mid Career researcher?

Do you think you have a strong track record?

Interested in an academic career?

...

**Please come talk to me... or email**